

MIMETIC Series | Medium duty robot
Model: SF20 - K1735

The MIMETIC is a medium payload industrial robot with a superior working range, advanced servo control technology, and an extremely rigid arm, significantly reducing cycle times and ensuring high productivity.

MIMETIC is a complete solution for medium payload class industrial robots to secure your future planning and production investment. From 20 kg up to 120 kg of fine load breakdown.

It is the perfect solution to ensure accuracy and production quality. Whether handling, machine loading/unloading, painting, stamping, palletizing, grinding, picking/packing, or assembly/distribution. In addition, you will have the freedom to choose the robot corresponding to your actual needs for greater efficiency and economic benefits.

All MIMETIC series are equipped with LIKEPRECISION technology, he ultra-precise RV Precision Gearbox, which enables the robot to take full advantage of its advantages even at high operating speeds.

Applications



SF20 - K1735 Data Overview

Model	SF20 - K1735	
Structure	Vertically Articulated	
Number of Axis	6	
Radius	1735mm	
Payload	20kg	
Repeatability	±0.05mm	
Drive Mode	AC Servo Motor	
Maximum Speed	J1	135°/s
	J2	135°/s
	J3	135°/s
	J4	300°/s
	J5	300°/s
	J6	500°/s
Range of Motion	J1	±175°
	J2	+68°/-150°
	J3	+150°/-75°
	J4	±178°
	J5	+135°/-125°
	J6	±720°
Allowable Moment	J4	42N·m
	J5	42N·m
	J6	23N·m
Allowable Inertia	J4	1.26kg·m ²
	J5	1.26kg·m ²
	J6	0.49kg·m ²
Protection Rating	IP 65	
Operating Conditions	Temp.	0-45°C
	Humidity	Below 95%RH
	Vibration	Below 4.9m/s ²
	Other	Eliminate Signal Noise
Base Size	370*370mm	
Height	1563mm	
Weight	206KG	
Mounting Positions	Floor, Wall, Ceiling	
Power Consumption	3.25kVA	

SF20 - K1735 Range of Motion

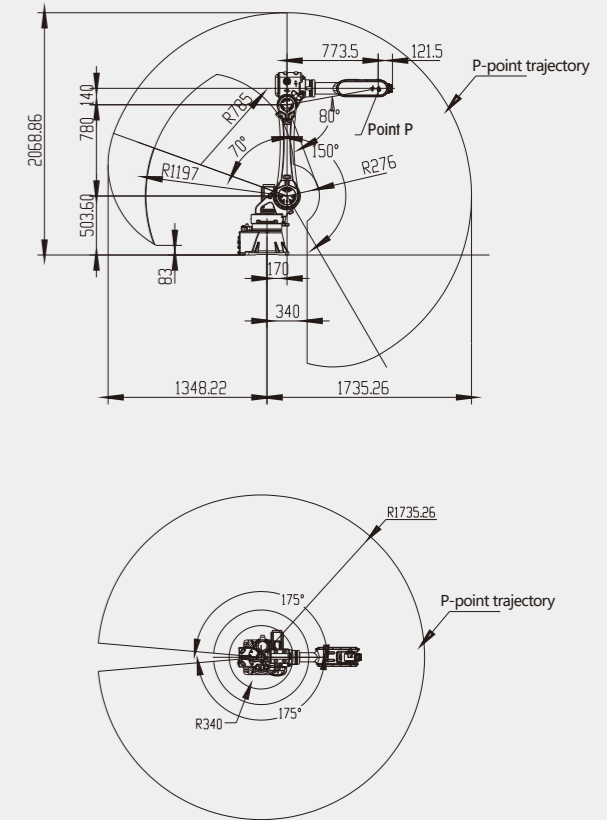

SF20 - K1735 Wrist Load Curve Chart

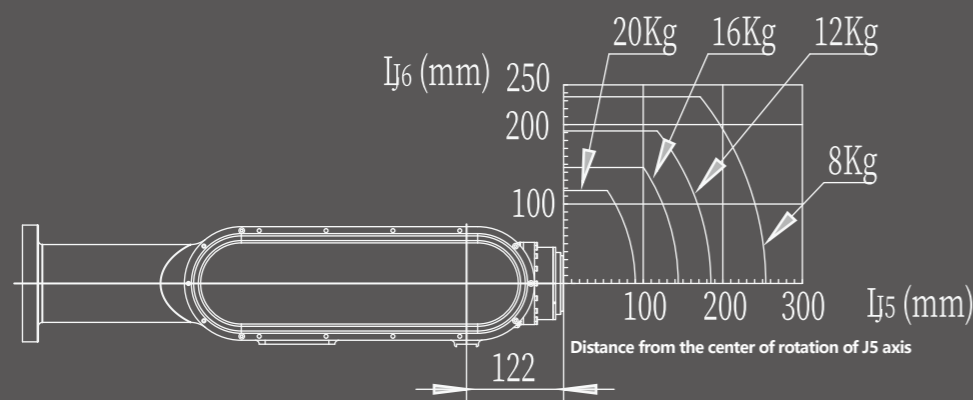

SF20 - K1735 Load Range Curve Chart

SF20 - K1735 External & Installation Dimensions

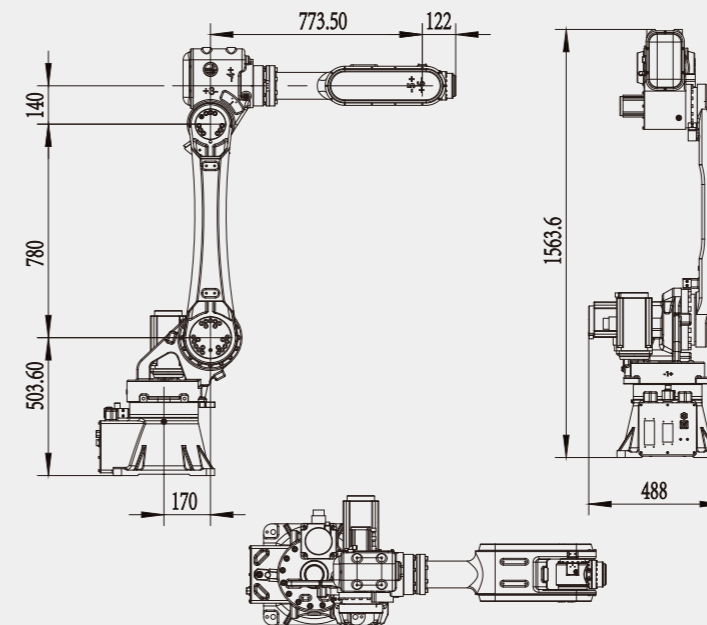

A-Way Diagram (End Flange Mounting Dimensions)

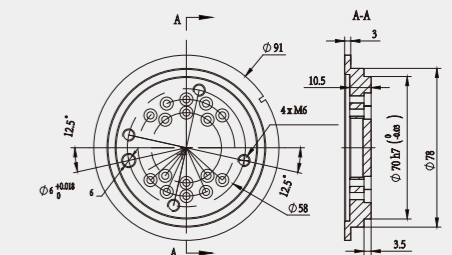

B-Way Diagram (Base Mounting Dimensions)

