



**MIMETIC Series | Medium duty robot**  
**Model: SF30 - C1850**

The MIMETIC is a medium payload industrial robot with a superior working range, advanced servo control technology, and an extremely rigid arm, significantly reducing cycle times and ensuring high productivity.

MIMETIC is a complete solution for medium payload class industrial robots to secure your future planning and production investment. From 20 kg up to 120 kg of fine load breakdown.

It is the perfect solution to ensure accuracy and production quality. Whether handling, machine loading/unloading, painting, stamping, palletizing, grinding, picking/packing, or assembly/distribution. In addition, you will have the freedom to choose the robot corresponding to your actual needs for greater efficiency and economic benefits.

All MIMETIC series are equipped with LIKEPRECISION technology, the ultra-precise RV Precision Gearbox, which enables the robot to take full advantage of its advantages even at high operating speeds.

**Applications**



**SF30 - C1850 Data Overview**

<b>Model</b>	SF30 - C1850	
<b>Structure</b>	Vertically Articulated	
<b>Number of Axis</b>	6	
<b>Radius</b>	1856mm	
<b>Payload</b>	30kg	
<b>Repeatability</b>	±0.06mm	
<b>Drive Mode</b>	AC Servo Motor	
<b>Maximum Speed</b>	J1	170°/s
	J2	170°/s
	J3	170°/s
	J4	350°/s
	J5	230°/s
	J6	230°/s
<b>Range of Motion</b>	J1	±170°
	J2	+100°/-157°
	J3	+98°/-76°
	J4	±180°
	J5	+125°/-125°
	J6	±720°
<b>Allowable Moment</b>	J4	42N·m
	J5	42N·m
	J6	23N·m
<b>Allowable Inertia</b>	J4	1.26kg·m <sup>2</sup>
	J5	1.26kg·m <sup>2</sup>
	J6	0.49kg·m <sup>2</sup>
<b>Protection Rating</b>	IP 65	
<b>Operating Conditions</b>	Temp.	0-45°C
	Humidity	Below 95%RH
	Vibration	Below 4.9m/s <sup>2</sup>
	Other	Eliminate Signal Noise
<b>Base Size</b>	396*396mm	
<b>Height</b>	1602.5mm	
<b>Weight</b>	228KG	
<b>Mounting Positions</b>	Floor, Wall, Ceiling	
<b>Power Consumption</b>	3.8kVA	

**SF30 - C1850 Range of Motion**

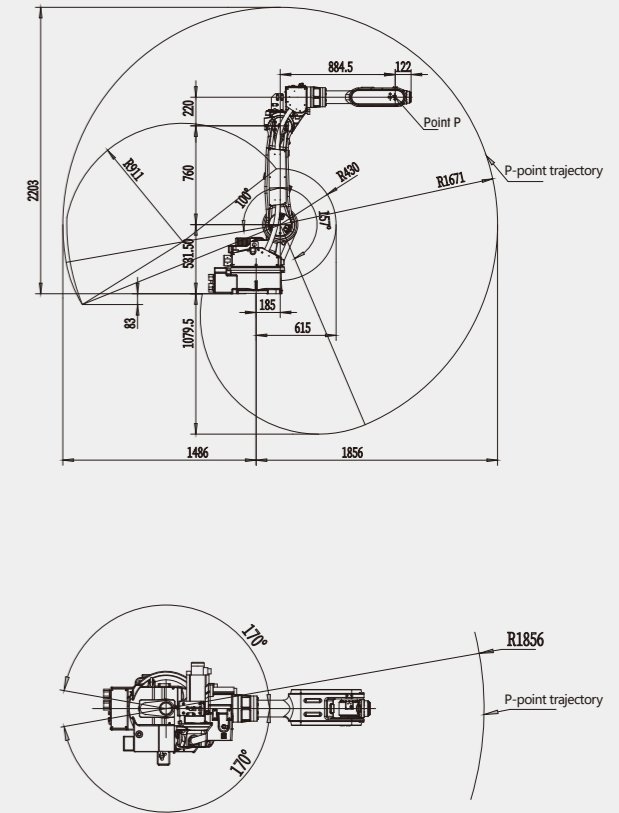

**SF30 - C1850 Wrist Load Curve Chart**

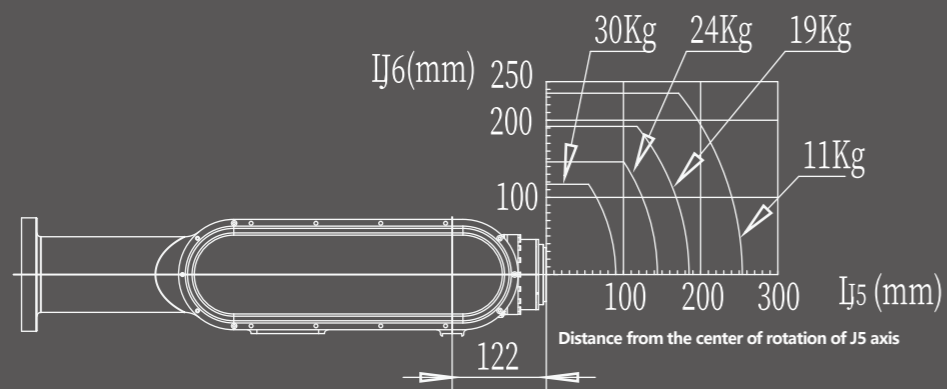

SF30 - C1850 Load Range Curve Chart

**SF30 - C1850 External & Installation Dimensions**

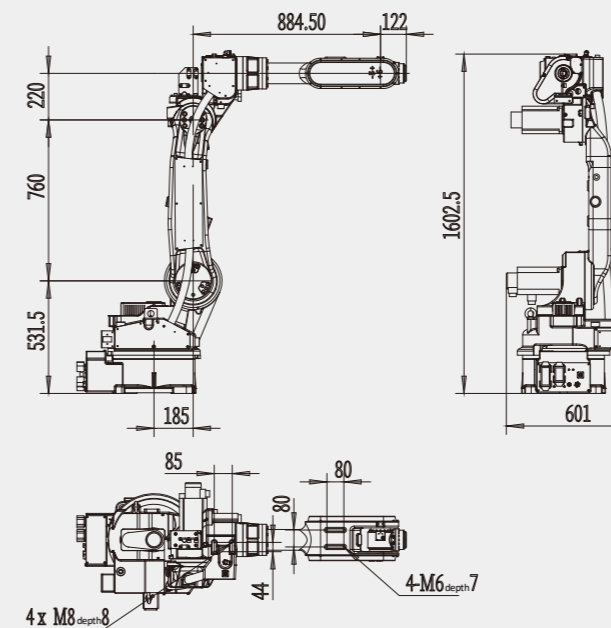

**A-Way Diagram (End Flange Mounting Dimensions)**

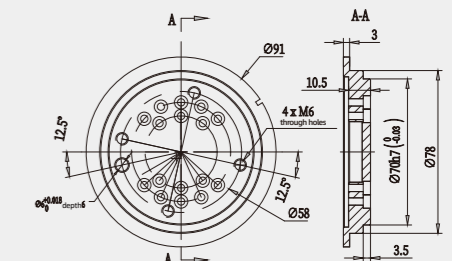

**B-Way Diagram (Base Mounting Dimensions)**

