



MIMETIC Series | Medium duty robot
Model: SF50 - C2185

The MIMETIC is a medium payload industrial robot with a superior working range, advanced servo control technology, and an extremely rigid arm, significantly reducing cycle times and ensuring high productivity.

MIMETIC is a complete solution for medium payload class industrial robots to secure your future planning and production investment. From 20 kg up to 120 kg of fine load breakdown.

It is the perfect solution to ensure accuracy and production quality. Whether handling, machine loading/unloading, painting, stamping, palletizing, grinding, picking/packing, or assembly/distribution. In addition, you will have the freedom to choose the robot corresponding to your actual needs for greater efficiency and economic benefits.

All MIMETIC series are equipped with LIKEPRECISION technology, he ultra-precise RV Precision Gearbox, which enables the robot to take full advantage of its advantages even at high operating speeds.

Applications



SF50 - C2185 Data Overview

Model	SF50 - C2185	
Structure	Vertically Articulated	
Number of Axis	6	
Radius	2185mm	
Payload	50kg	
Repeatability	±0.08mm	
Drive Mode	AC Servo Motor	
Maximum Speed	J1	109°/s
	J2	125°/s
	J3	140°/s
	J4	200°/s
	J5	210°/s
	J6	190°/s
Range of Motion	J1	±172°
	J2	+72°/-140°
	J3	+172°/-78°
	J4	±360°
	J5	+124°/-121°
	J6	±360°
Allowable Moment	J4	185N·m
	J5	185N·m
	J6	126N·m
Allowable Inertia	J4	12kg·m ²
	J5	12kg·m ²
	J6	9.6kg·m ²
Protection Rating	IP 65	
Operating Conditions	Temp.	0-45°C
	Humidity	Below 95%RH
	Vibration	Below 4.9m/s ²
	Other	Eliminate Signal Noise
Base Size	630*570mm	
Height	1820mm	
Weight	550KG	
Mounting Positions	Floor, Wall, Ceiling	
Power Consumption	5kVA	

SF50 - C2185 Range of Motion

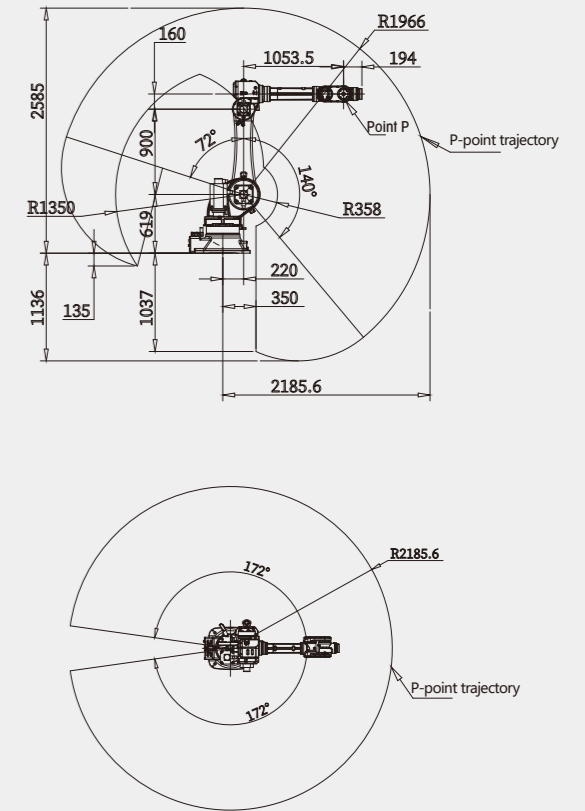

SF50 - C2185 Wrist Load Curve Chart

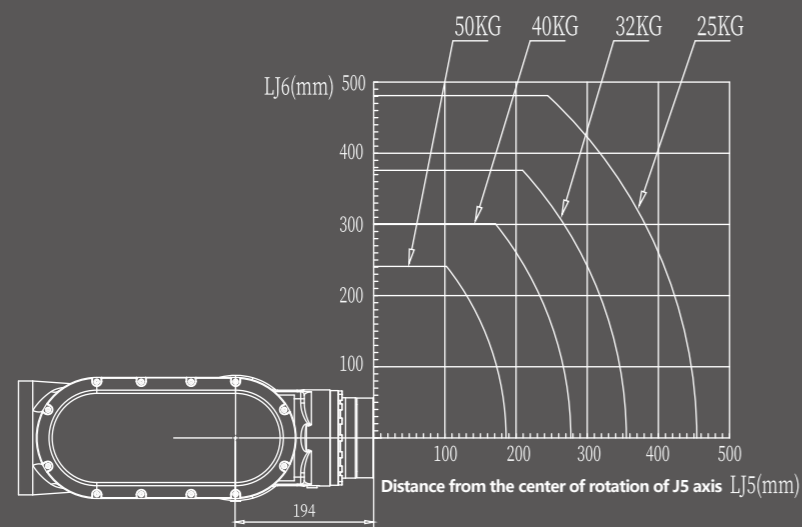

SF50 - C2185 Load Range Curve Chart

SF50 - C2185 External & Installation Dimensions

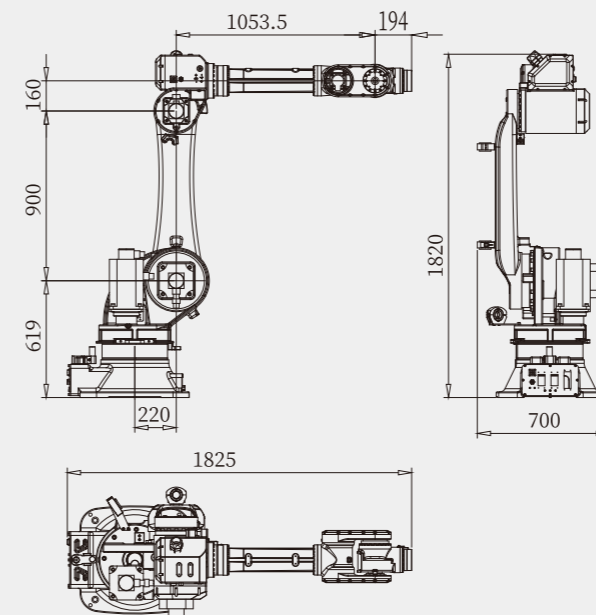

A-Way Diagram (End Flange Mounting Dimensions)

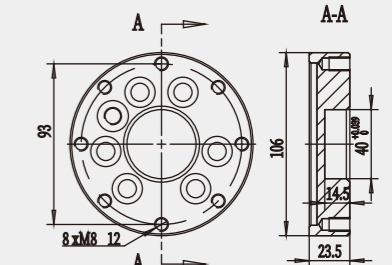

B-Way Diagram (Base Mounting Dimensions)

