

PRENTIC Series | Desktop robots
Model: SF7-K759

The ultra-compact PRENTIC series are compact and flexible tabletop robots that are powerful, fast, and efficient, enabling extremely precise and agile robots for various applications in the medium load class, no matter how small the parts are.

PRENTIC has a maximum load capacity of 7 kg and an arm span of 737.5 mm. With the introduction of the PRENTIC series, We are redefining the benchmark for robots in the tabletop class below 7 kg.

The PRENTIC series is ideal for applications in tight spaces such as 3C, handling, painting, welding, pick/pack, and assembly /distribution.

This desktop-class robot is tailored for the pursuit of performance and throughput.

Applications



SF7-K759 Data Overview

Model	SF7-K759	
Structure	Vertically Articulated	
Number of Axis	6	
Radius	737.5mm	
Payload	7kg	
Repeatability	±0.04mm	
Drive Mode	AC Servo Motor	
Maximum Speed	J1	305°/s
	J2	280°/s
	J3	300°/s
	J4	300°/s
	J5	406°/s
	J6	600°/s
Range of Motion	J1	±171°
	J2	+65°/-141°
	J3	+170°/-66°
	J4	±180°
	J5	±119°
	J6	±360°
Allowable Moment	J4	15.6N·m
	J5	15.6N·m
	J6	8.5N·m
Allowable Inertia	J4	0.43kg·m ²
	J5	0.43kg·m ²
	J6	0.13kg·m ²
Protection Rating	IP 65	
Operating Conditions	Temp.	0-45°C
	Humidity	Below 95%RH
	Vibration	Below 4.9m/s ²
	Other	Eliminate Signal Noise
Base Size	210*235mm	
Height	880mm	
Weight	48KG	
Mounting Positions	Floor	
Power Consumption	1.5kVA	

SF7-K759 Range of Motion

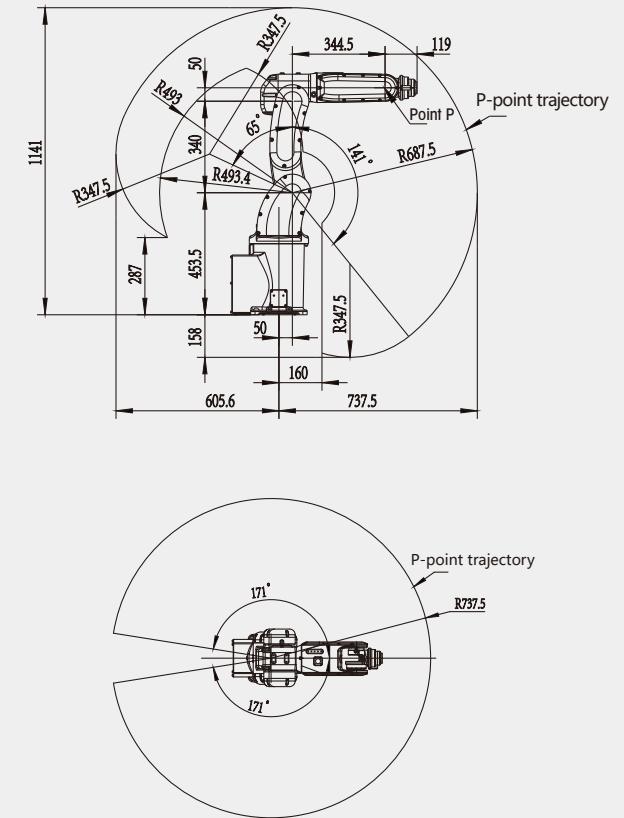

SF7 - K759 Wrist Load Curve Chart

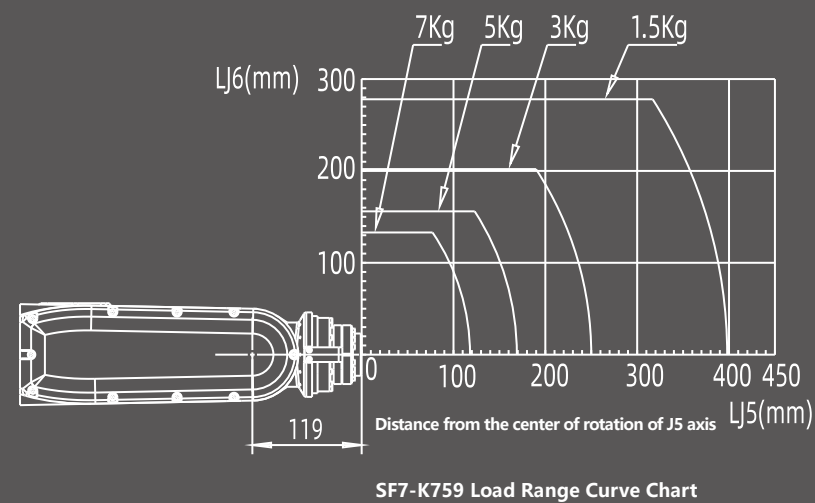

SF7-K759 External & Installation Dimensions

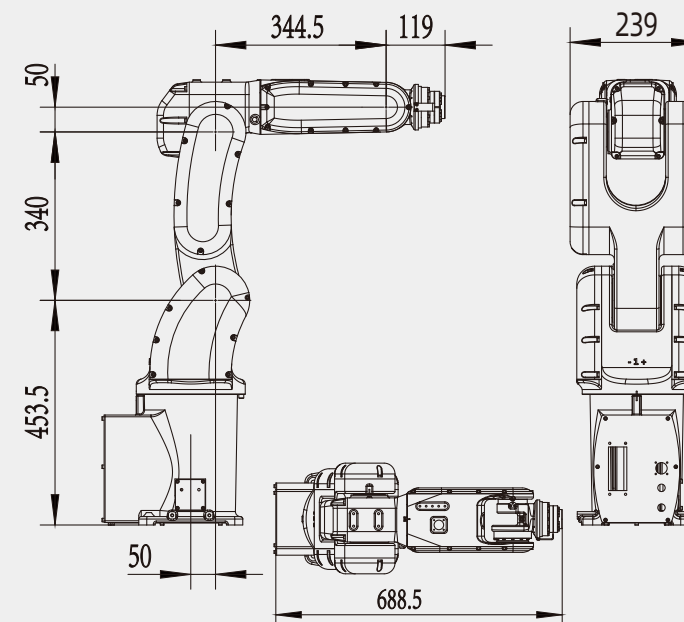

A-Way Diagram (End Flange Mounting Dimensions)

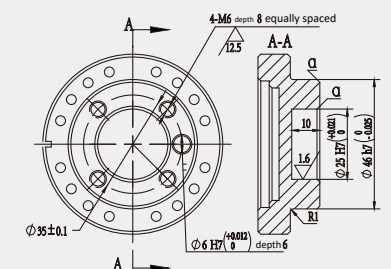

B-Way Diagram (Base Mounting Dimensions)

