



**PRESS Series | Stamping Press Robot**  
**Model: SF15 - C1538**

The PRESS is designed for high speed press handling. With its high precision and unmatched productivity, the PRESS has become the best productivity tool for press handling loading and palletizing.

The PRESS pin optimizes the efficiency and productivity of the overall press shop, with different combinations for different applications and a solid foundation for every press command due to LIKEHEATTREATMENT thermal technology.

All PRESS series are equipped with LIKEPRECISION technology, the ultra-precise RV Precision Gearbox, which allows the robot to take full advantage of its advantages even at high operating speeds.

**Applications**

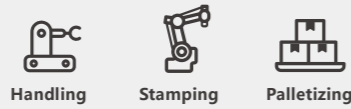

**SF15 - C1538 Data Overview**

<b>Model</b>	SF15 - C1538	
<b>Structure</b>	Vertically Articulated	
<b>Number of Axis</b>	4	
<b>Radius</b>	1610mm	
<b>Payload</b>	15kg	
<b>Repeatability</b>	±0.06mm	
<b>Drive Mode</b>	AC Servo Motor	
<b>Maximum Speed</b>	J1	150°/s
	J2	150°/s
	J3	160°/s
	J4	300°/s
	J5	/
	J6	/
<b>Range of Motion</b>	J1	±165°
	J2	+40°/-82°
	J3	+78°/-75°
	J4	±360°
<b>Allowable Moment</b>	J4	196N·m
	J5	/
	J6	/
<b>Allowable Inertia</b>	J4	0.52kg·m <sup>2</sup>
	J5	/
	J6	/
<b>Protection Rating</b>	IP 65	
<b>Operating Conditions</b>	Temp.	0-45°C
	Humidity	Below 95%RH
	Vibration	Below 4.9m/s <sup>2</sup>
	Other	Eliminate Signal Noise
<b>Base Size</b>	384*384mm	
<b>Height</b>	1421mm	
<b>Weight</b>	181KG	
<b>Mounting Positions</b>	Floor, Wall, Ceiling	
<b>Power Consumption</b>	2.5kVA	

**SF15 - C1538 Range of Motion**

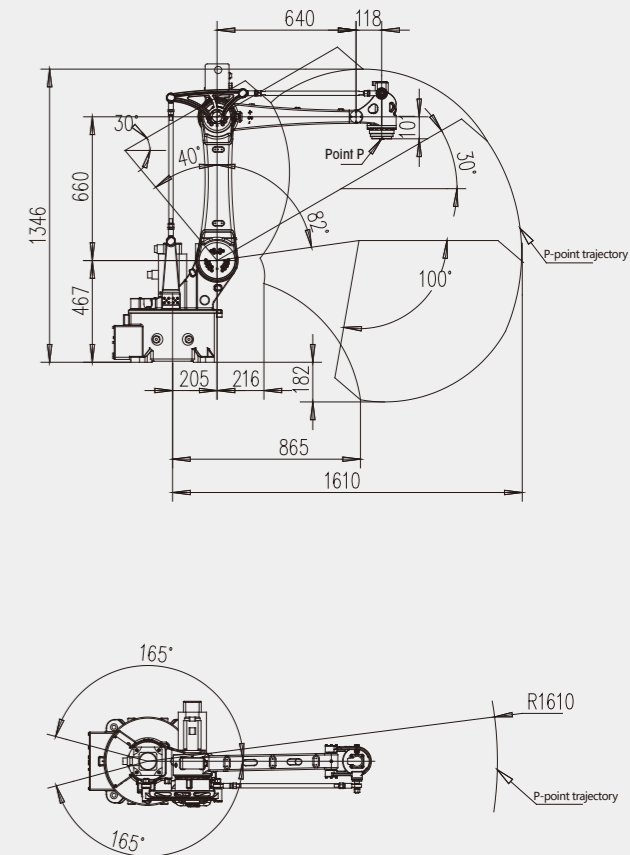

**SF15 - C1538 Wrist Load Curve Chart**

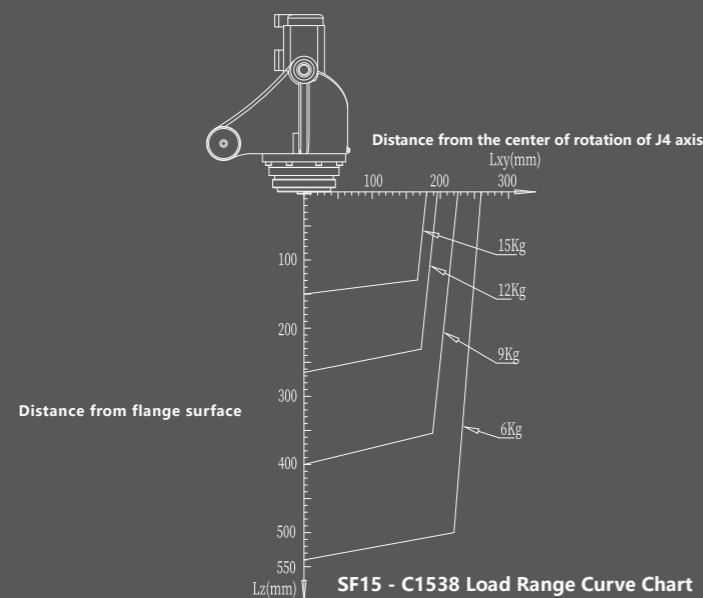

SF15 - C1538 Load Range Curve Chart

**SF15 - C1538 External & Installation Dimensions**

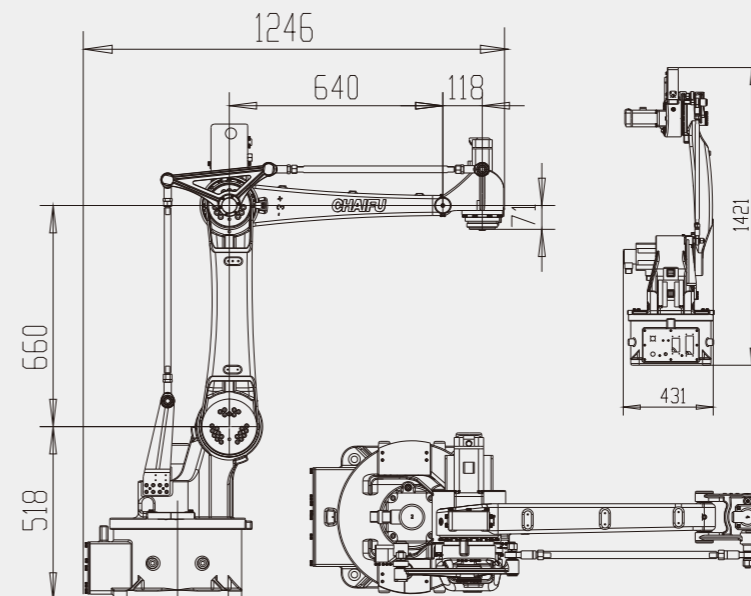

**A-Way Diagram (End Flange Mounting Dimensions)**

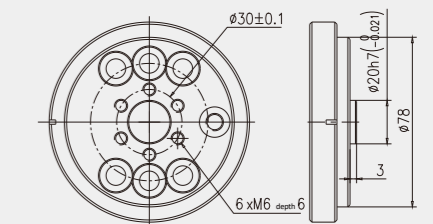

**B-Way Diagram (Base Mounting Dimensions)**

